

BILINCSEK - KAPCSOK

- Anyag: acél S 235 - tűzhorganyzott (Fe/Zn); Réz E-Cu 57F25; Rozsdamentes 1.4301 (304 / A2); Saválló 1.4401 (316 / A4); Aluötözet AlMgSi
- Használat: a földelési elemek áramvezetős összekötéséhez

CLAMPS

- Material: steel S235 - hot-dip galvanized (Fe/Zn); Copper - E-Cu 57F25; Stainless steel - grade 1.4301 (304 / A2), on demand 1.4401 (316 / A4), Aluminium - AlMgSi
- Use: for connecting the lightning protection system elements

FÖLDELŐ KAPOCS PÁRHUZAMOS KÖTÉSHEZ EARTHING ROD CLAMP

Anyag (Material)	Cikkszám (Code)	(Part no.)	D (mm)	Súly (Weight) kg
Fe/Zn	SJ 01	f611120	Ø 20	0,40
	SJ 02	f611128	Ø 25	0,40
Réz	SJ 01	f611120 Cu	Ø 20	0,48
	SJ 02	f611128 Cu	Ø 25	0,48
Rozsdamentes	SJ 01	f611120 A2	Ø 20	0,38
	SJ 02	f611128 A2	Ø 25	0,38

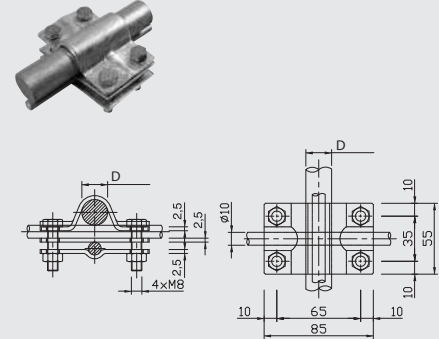

FÖLDELŐ KAPOCS PÁRHUZAMOS KÖTÉSHEZ EARTHING ROD CLAMP

Anyag (Material)	Cikkszám (Code)	(Part no.)	D (mm)	Súly (Weight) kg
Fe/Zn	SJ 01 m	f611119	Ø 20	0,16
	SJ 02 m	f611127	Ø 25	0,17
	SJ 02 s podl.	f611129	Ø 25	0,23
Rozsdamentes	SJ 01 m	f611119 A2	Ø 20	0,16
	SJ 02 m	f611127 A2	Ø 25	0,16

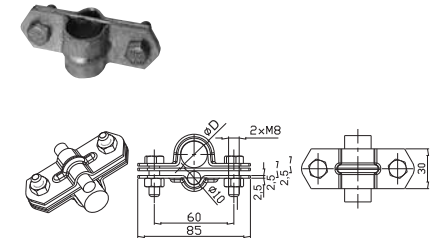

FÖLDELŐ KAPOCS EARTHING ROD CLAMP

Anyag (Material)	Cikkszám (Code)	(Part no.)	D (mm)	Súly (Weight) kg
Fe/Zn	SJ 03	f611130	Ø 25	0,55

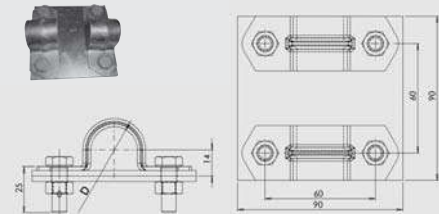

PÁRHUZAMOS KAPOCS PARALLEL CLAMP FOR INTERCEPTION ROD

Anyag (Material)	Cikkszám (Code)	(Part no.)	D (mm)	Súly (Weight) kg
Bronz + Rozsdamentes	SJ 3F	f000191/1	Ø30	0,11

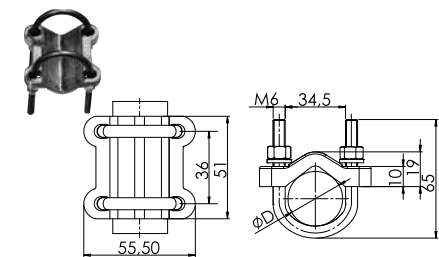

KERESZT-KÖTÉS KAPOCS CROSS CLAMP

Anyag (Material)	Cikkszám (Code)	(Part no.)	D (mm)	Súly (Weight) kg
Fe/Zn	SK	f612110	Ø 8-10	0,22
Réz	SK	f612110 Cu	Ø 8-10	0,25

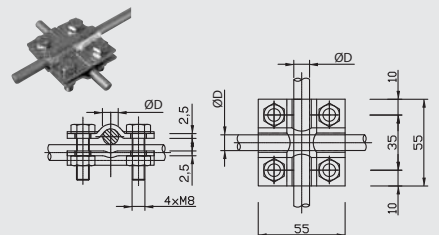

KERESZT KAPOCS CROSS CLAMP

Anyag (Material)	Cikkszám (Code)	(Part no.)	D (mm)	Súly (Weight) kg
Rozsdamentes	SK	f612110 A2	Ø 8-10	0,10

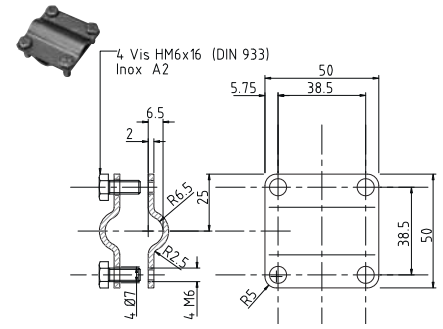

ÖSSZEKÖTŐ KAPOCS FÉM SZERKEZETEKRE METAL PARTS CONNECTING CLAMP

Anyag (Material)	Cikkszám (Code)	(Part no.)	D (mm)	Súly (Weight) kg
Fe/Zn	SP 1	f613212	Ø 8-10	0,15
Réz	SP 1	f613212 Cu	Ø 8-10	0,18
Rozsdamentes	SP 1	f613212 A2	Ø 8-10	0,14

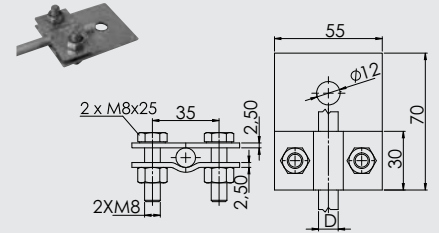

ÖSSZEKÖTŐ KAPOCS FÉM SZERKEZETEKRE METAL PARTS CONNECTING CLAMP

Anyag (Material)	Cikkszám (Code)	(Part no.)	D (mm)	Súly (Weight) kg
Fe/Zn	SP 2	f613213	Ø 8-10	0,14
Réz	SP 2	f613213 Cu	Ø 8-10	0,16
Rozsdamentes	SP 2	f613213 A2	Ø 8-10	0,13

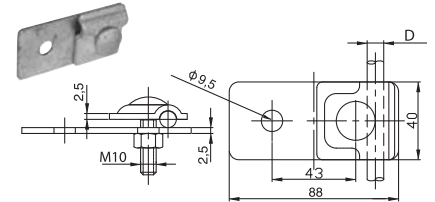

VIZSGÁLÓ ÖSSZEKÖTŐ KAPOCS TESTING CLAMP

Anyag (Material)	Cikkszám (Code)	(Part no.)	D (mm)	Súly (Weight) kg
Fe/Zn	SZ	t614109	Ø 8-10	0,17
Réz	SZ	f614110 Cu	Ø 8-10	0,12
Rozsdamentes	SZ	f614110 A2	Ø 8-10	0,10

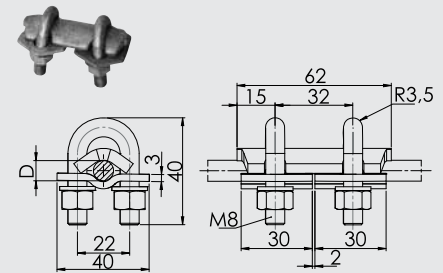

VIZSGÁLÓ ÖSSZEKÖTŐ KAPOCS, KICSI TESTING CLAMP

Anyag (Material)	Cikkszám (Code)	(Part no.)	D (mm)	Súly (Weight) kg
Fe/Zn	SZ pl malá	f614113	Ø 8-10	0,13
	SZ pl malá A2*	f614112	Ø 8-10	0,13

pl = acél lemez / pl = steel plate, * A2 = Rozsdamentes furatok / A2 = StSt nuts

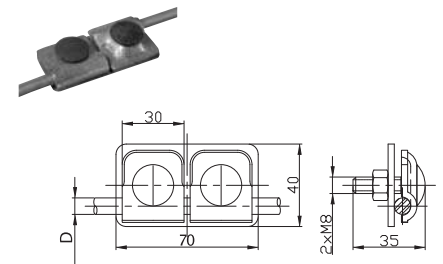

VIZSGÁLÓ ÖSSZEKÖTŐ KAPOCS NAGY TESTING CLAMP

Anyag (Material)	Cikkszám (Code)	(Part no.)	D (mm)	Súly (Weight) kg
Fe/Zn	SZ pl velká	f614111	Ø 8-10	0,24
Rozsdamentes	SZ pl velká	f614111 A2	Ø 8-10	0,22

pl = acél lemez / pl = steel plate

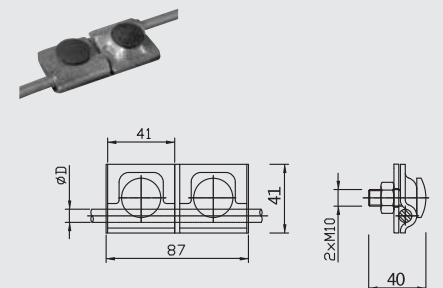

ÖSSZEKÖTŐ KAPOCS - 2 CSAVARRAL, KÖZÉPLEMEZZEL
CONNECTING CLAMP - 2 BOLTS WITH MIDDLE PLATE

Anyag (Material)	Cikkszám (Code)	(Part no.)	D (mm)	Súly (Weight) kg
Fe/Zn	SS s. p. 2sk	f613112	Ø 8-10	0,16
Réz	SS s. p. 2sk	f613112 Cu	Ø 8-10	0,19
Rozsdamentes	SS s. p. 2sk	f613112 A2	Ø 8-10	0,15
Alumínium	SS s. p. 2sk	f613112 Al	Ø 8-10	0,10

s. p. 2sk = 2 csavarral, középső lemezzel / with 2 bolts, and middle plate

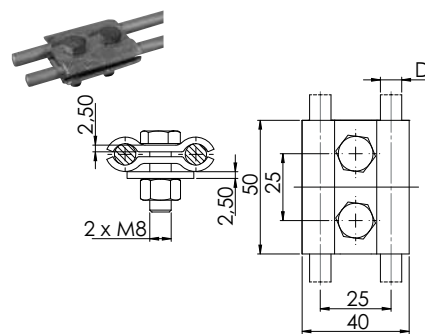
ÖSSZEKÖTŐ KAPOCS - 2 CSAVARRAL, KÖZÉPLEMEZ NÉLKÜL
CONNECTING CLAMP - 2 BOLTS WITHOUT MIDDLE PLATE

Anyag (Material)	Cikkszám (Code)	(Part no.)	D (mm)	Súly (Weight) kg
Fe/Zn	SS b. p. 2sk	f613111	Ø 8-10	0,13
Réz	SS b. p. 2sk	f613111 Cu	Ø 8-10	0,16
Rozsdamentes	SS b. p. 2sk	f613111 A2	Ø 8-10	0,13
Alumínium	SS b. p. 2sk	f613111 Al	Ø 8-10	0,09

b. p. 2sk = 2 csavarral, középső lemez nélkül / with 2 bolts, without middle plate

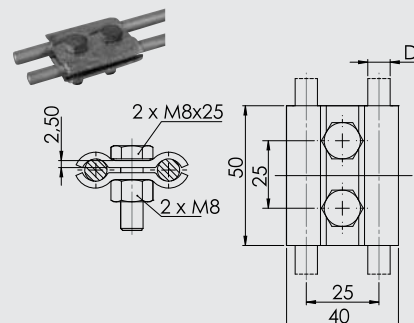
ÖSSZEKÖTŐ KAPOCS - 1 CSAVARRAL, KÖZÉPLEMEZ NÉLKÜL
CONNECTING CLAMP - 1 BOLT WITHOUT MIDDLE PLATE

Anyag (Material)	Cikkszám (Code)	(Part no.)	D (mm)	Súly (Weight) kg
Fe/Zn	SS b. p. 1sk	f613110	Ø 8-10	0,12

b. p. 1sk = 1 csavarral, középső lemez nélkül / with 1 bolt, without middle plate

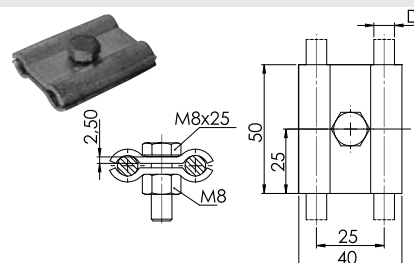
ÖSSZEKÖTŐ KAPOCS, KICSI - 2 CSAVARRAL, KÖZÉPLEMEZZEL
SMALL CONNECTING CLAMP - 2 BOLTS WITH MIDDLE PLATE

Anyag (Material)	Cikkszám (Code)	(Part no.)	D (mm)	Súly (Weight) kg
Fe/Zn	SS malá s. p. 2sk	f613119	Ø 8-10	0,13
Réz	SS malá s. p. 2sk	f613119 Cu	Ø 8-10	0,15
Rozsdamentes	SS malá s. p. 2sk	f613119 A2	Ø 8-10	0,12

s. p. 2sk = 2 csavarral, középső lemezzel / with 2 bolts, and middle plate

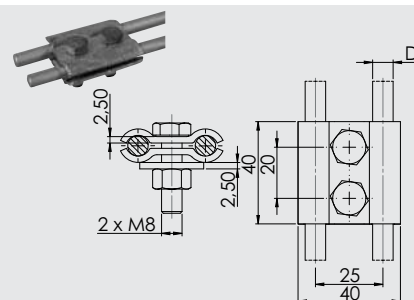

ÖSSZEKÖTŐ KAPOCS, KICSI - 2 CSAVARRAL, KÖZÉPLEMEZ NÉLKÜL
SMALL CONNECTING CLAMP - 2 BOLTS WITHOUT MIDDLE PLATE

Anyag (Material)	Cikkszám (Code)	(Part no.)	D (mm)	Súly (Weight) kg
Fe/Zn	SS malá b. p. 2sk	f613118	Ø 8-10	0,11
Réz	SS malá b. p. 2sk	f613118 Cu	Ø 8-10	0,13
Rozsdamentes	SS malá b. p. 2sk	f613118 A2	Ø 8-10	0,10

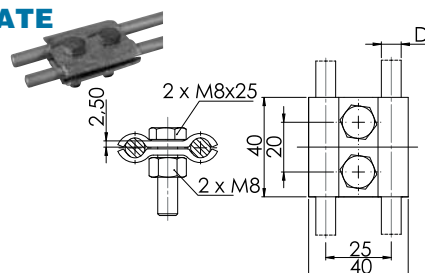
b. p. 2sk = 2 csavarral, középső lemez nélkül / with 2 bolts, without middle plate

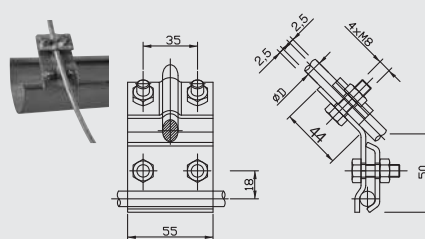

ERESZCSATORNA KAPOCS
CONNECTING CLAMP FOR GUTTERS

Anyag (Material)	Cikkszám (Code)	(Part no.)	D (mm)	Súly (Weight) kg
Fe/Zn	SO	f613312	Ø 8-10	0,29
Réz	SO	f613312 Cu	Ø 8-10	0,35
Rozsdamentes	SO	f613312 A2	Ø 8-10	0,28
Alumínium	SO	f613312 Al	Ø 8-10	0,17

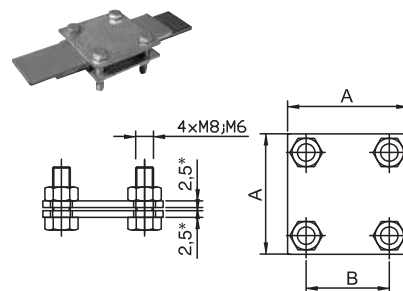

ÖSSZEKÖTŐ KAPOCS LAPOSVEZETŐHÖZ DEFLECTING CONNECTING CLAMP

Anyag (Material)	Cikkszám (Code)	(Part no.)	A (mm)	B (mm)	Súly (Weight) kg
Fe/Zn	SR 01	f616111	45	28	0,16
	SR 02 (M6)	f616112	55	38	0,18
	SR 02 (M8)	f616122	55	38	0,22
	SR 02 (M8) s podl.	f616123	55	38	0,22
Réz	SR 01	f616111 Cu	45	28	0,17
	SR 02 (M6)	f616112 Cu	55	38	0,22
	SR 02 (M8)	f616122 Cu	55	38	0,25
	SR 02 (M8) s podl.	f616123 Cu	55	38	0,26
Rozsdamentes	SR 01	f616111 A2	45	28	0,15
	SR 02 (M6)	f616112 A2	55	38	0,17
	SR 02 (M8)	f616122 A2	55	38	0,21
	SR 02 (M8) s podl.	f616123 A2	55	38	0,21



* Az SR 01 anyagvastagsága 3 mm

* Material thickness for SR 01 is 3 mm

FÖLDELŐ KAPOCS EARTHING CLAMP

Anyag (Material)	Cikkszám (Code)	(Part no.)	D (mm)	Súly (Weight) kg
Fe/Zn	SR 03 A	f616211	Ø 8-10	0,21
Réz	SR 03 A	f616211 Cu	Ø 8-10	0,23
Rozsdamentes	SR 03 A	f616211 A2	Ø 8-10	0,20

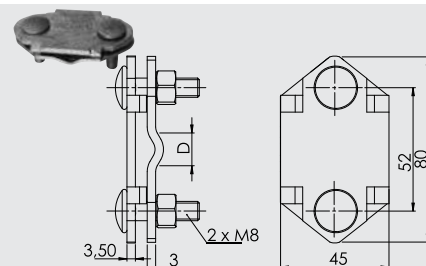

FÖLDELŐ KAPOCS EARTHING CLAMP

Anyag (Material)	Cikkszám (Code)	(Part no.)	D (mm)	Súly (Weight) kg
Fe/Zn	SR 03 B	f616212	Ø 8-10	0,20
Réz	SR 03 B	f616212 Cu	Ø 8-10	0,22
Rozsdamentes	SR 03 B	f616212 A2	Ø 8-10	0,19
Alumínium	SR 03 B	f616212 Al	Ø 8-10	0,10

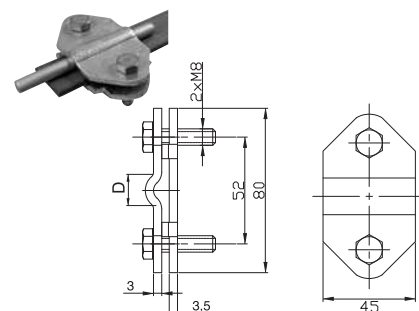

FÖLDELŐ KAPOCS EARTHING CLAMP

Anyag (Material)	Cikkszám (Code)	(Part no.)	D (mm)	Súly (Weight) kg
Fe/Zn	SR 03 C	f616213	Ø 8-10	0,21

Rozsdamentes furattal / with StSt nuts

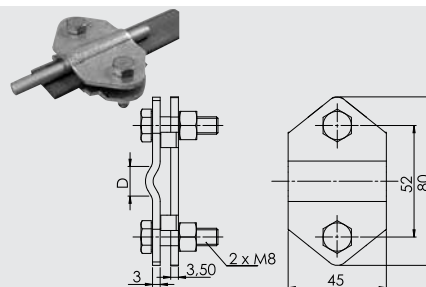

FÖLDELŐ KAPOCS EARTHING CLAMP

Anyag (Material)	Cikkszám (Code)	(Part no.)	D (mm)	Súly (Weight) kg
Fe/Zn	SR 03 D	f616214	Ø 8-10	0,13
Rozsdamentes	SR 03 D	f616214 A2	Ø 8-10	0,12

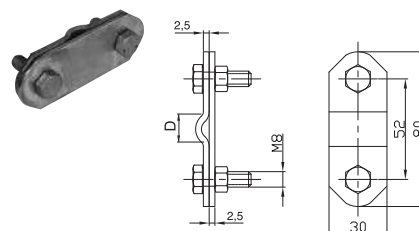

FÖLDELŐ KAPOCS EARTHING CLAMP

Anyag (Material)	Cikkszám (Code)	(Part no.)	D (mm)	Súly (Weight) kg
Fe/Zn	SR 03 E	f616215	Ø 8-10	0,13
Réz	SR 03 E	f616215 Cu	Ø 8-10	0,15
Rozsdamentes	SR 03 E	f616215 A2	Ø 8-10	0,13
Alumínium	SR 03 E	f616215 Al	Ø 8-10	0,07

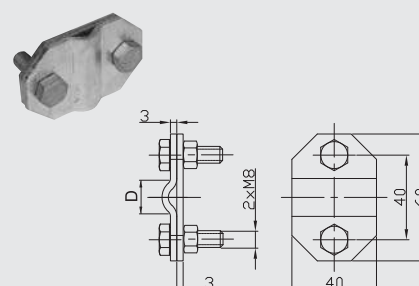

FÖLDELŐ KAPOCS
EARTHING CLAMP

Anyag (Material)	Cikkszám (Code)	(Part no.)	D (mm)	Súly (Weight) kg
Fe/Zn	SR 03 E A2	f616216	Ø 8-10	0,14

Rozsdamentes furattal / with StSt nuts

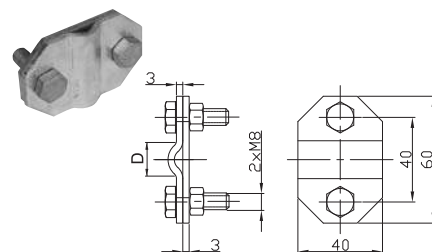

ÖSSZEKÖTŐ KAPOCS
CONNECTING CLAMP

Anyag (Material)	Cikkszám (Code)	(Part no.)	D (mm)	Súly (Weight) kg
Fe/Zn	SM 8	f613116	Ø 8	0,08
	SM 10	f613117	Ø 10	0,09
Rozsdamentes	SM 8	f613116 A2	Ø 8	0,08
	SM 10	f613117 A2	Ø 10	0,08

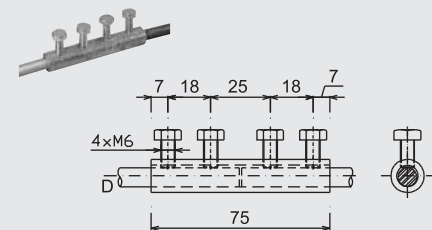

UNIVERZÁLIS KAPOCS
UNIVERSAL CLAMP

Anyag (Material)	Cikkszám (Code)	(Part no.)	D (mm)	Súly (Weight) kg
Fe/Zn	SU	f613113	Ø 8-10	0,17
Réz	SU	f613113 Cu	Ø 8-10	0,19
Rozsdamentes	SU	f613113 A2	Ø 8-10	0,16

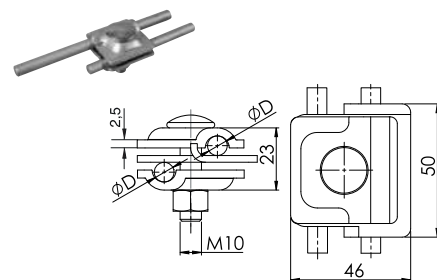

UNIVERZÁLIS KAPOCS
UNIVERSAL CLAMP

Anyag (Material)	Cikkszám (Code)	(Part no.)	D (mm)	Súly (Weight) kg
Fe/Zn	SUA	f613114	Ø 8-10	0,12
Réz	SUA	f613114 Cu	Ø 8-10	0,14
Rozsdamentes	SUA	f613114 A2	Ø 8-10	0,12

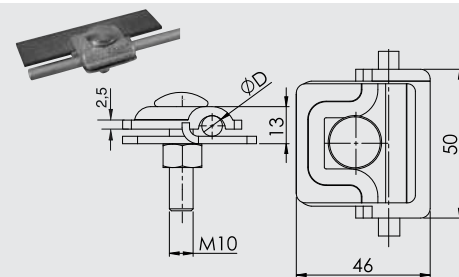

UNIVERZÁLIS KAPOCS
UNIVERSAL CLAMP

Anyag (Material)	Cikkszám (Code)	(Part no.)	A (mm)	B (mm)	M (mm)	Súly (Weight) kg
Fe/Zn	SUB	f613115	42	42	10	0,12
	SUB malá	f613125	35	35	8	0,07
Réz	SUB	f613115 Cu	42	42	10	0,14
	SUB malá	f613125 Cu	35	35	8	0,08
Rozsdamentes	SUB	f613115 A2	42	42	10	0,11

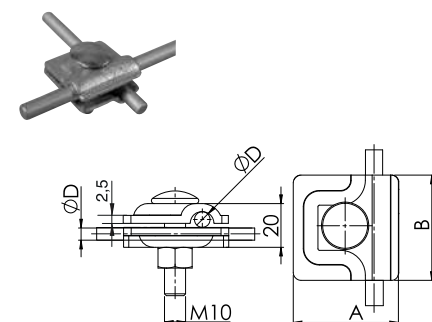

U-BILINCS
U-CLAMP TERMINAL (FOR FIXING TO CONCRETE STEEL REINFORCEMENTS)

Anyag (Material)	Cikkszám (Code)	(Part no.)	D (mm)	Súly (Weight) kg
Fe/Zn	SUS	f613120	Ø 16-48	0,11

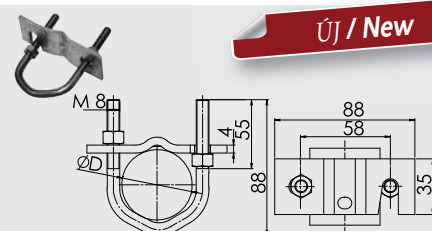

ÚJ / New

U-BILINCS 2 LEMEZSEL
U-CLAMP TERMINAL WITH 2 CLAMPING FRAMES

Anyag (Material)	Cikkszám (Code)	(Part no.)	D (mm)	Súly (Weight) kg
Fe/Zn	SUS s prílozkami	f613121	Ø 16-48	0,15

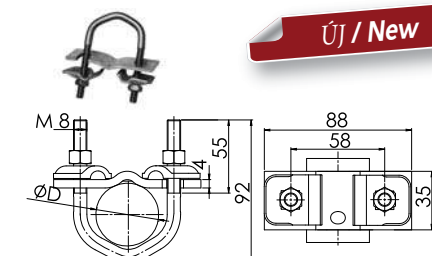

ÚJ / New

UNIVERZÁLIS CSŐKAPOCS SZALAG NÉLKÜL UNIVERSAL PIPE CLAMP WITHOUT STRIP

Anyag (Material)	Cikkszám (Code)	(Part no.)	D (mm)	Súly (Weight) kg
Fe/Zn	SUP bez pásika	f615110	Ø 8-10	0,125
Réz	SUP bez pásika	f615110 Cu	Ø 8-10	0,100
Rozsdamentes	SUP bez pásika	f615110 A2	Ø 8-10	0,090

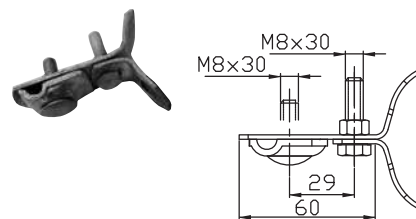

SZALAG UNIVERZÁLIS CSŐKAPOCSHOZ STRIP FOR UNIVERSAL PIPE CLAMP

Anyag (Material)	Cikkszám (Code)	(Part no.)	L (mm)	D (mm)	Súly (Weight) kg
Rozsdamentes	Pásik nerezový A2 0,5m	f615111	0,5 m	80-120	0,03
	Pásik nerezový A2 1,0m	f615111/1	1 m	80-250	0,06

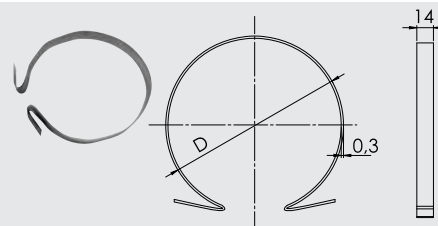

DIAGONÁLIS KERESZTKAPOCS DIAGONAL CROSS CLAMP

Anyag (Material)	Cikkszám (Code)	(Part no.)	D (mm)	Súly (Weight) kg
Fe/Zn	DKS 01	f612111	Ø 8-10	0,24
Rozsdamentes	DKS 01	f612111 A2	Ø 8-10	0,23

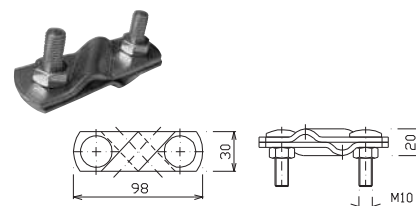

DIAGONÁLIS KERESZTKAPOCS DIAGONAL CROSS CLAMP

Anyag (Material)	Cikkszám (Code)	(Part no.)	D (mm)	Súly (Weight) kg
Fe/Zn	DKS 02	f612112	Ø 8-10	0,32
Rozsdamentes	DKS 02	f612112 A2	Ø 8-10	0,30

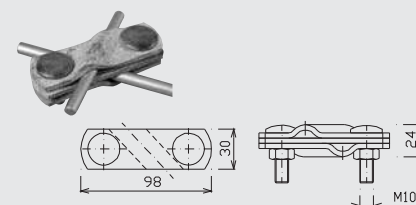

DIAGONÁLIS KERESZTKAPOCS DIAGONAL CROSS CLAMP

Anyag (Material)	Cikkszám (Code)	(Part no.)	Súly (Weight) kg
Fe/Zn	DKS 03	f612113	0,24
Rozsdamentes	DKS 03	f612113 A2	0,23

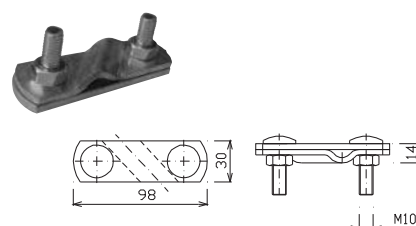

ELVÁLASZTÓ KAPOCS DISCONNECTING CLAMP

Anyag (Material)	Cikkszám (Code)	(Part no.)	Súly (Weight) kg
Fe/Zn	RS 1	f612114	0,16
Rozsdamentes	RS 1	f612114 A2	0,16

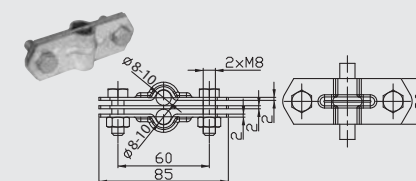

ELVÁLASZTÓ KAPOCS DISCONNECTING CLAMP

Anyag (Material)	Cikkszám (Code)	(Part no.)	Súly (Weight) kg
Fe/Zn	RS 2	f612115	0,14
Nerez (StSt)	RS 2	f612115 A2	0,13

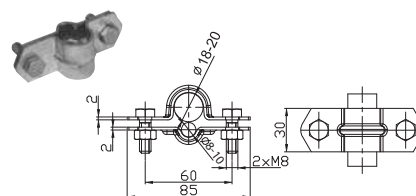

ELVÁLASZTÓ KAPOCS DISCONNECTING CLAMP

Anyag (Material)	Cikkszám (Code)	(Part no.)	Súly (Weight) kg
Fe/Zn	RS 3	f612116	0,13
Nerez (StSt)	RS 3	f612116 A2	0,12

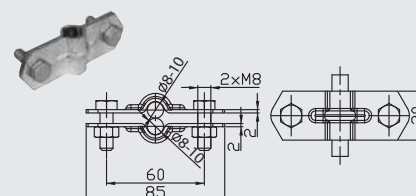

CSŐKAPOCS CONNECTING CLAMP FOR PIPELINE

Anyag (Material)	Cikkszám (Code)	(Part no.)	D (")	D (mm)	A (mm)	E (mm)	F (mm)	G (mm)	Súly (Weight) kg
Fe/Zn	ST 01	f615101	1/2"	21	104	50	30	40	0,27
	ST 02	f615102	3/4"	26,5	112	58	30	44	0,29
	ST 03	f615103	1"	33	137	72	35	53,5	0,35
	ST 04	f615104	1 1/4"	42	149	84	35	59,5	0,39
	ST 05	f615105	1 1/2"	48	155	90	35	62,5	0,40
	ST 06	f615106	2"	60	189	112	42	77	0,44
	ST 07	f615107	2 1/2"	75	207	130	42	86	0,48
	ST 08	f615108	3"	88	219	142	42	92	0,53
	ST 09	f615109	4"	113	250	175	42	92	0,62
Réz	ST 01	f615101 Cu	1/2"	21	104	50	30	40	0,27
	ST 02	f615102 Cu	3/4"	26,5	112	58	30	44	0,29
	ST 03	f615103 Cu	1"	33	137	72	35	53,5	0,36
	ST 04	f615104 Cu	1 1/4"	42	149	84	35	59,5	0,40
	ST 05	f615105 Cu	1 1/2"	48	155	90	35	62,5	0,41
	ST 06	f615106 Cu	2"	60	189	112	42	77	0,44
	ST 07	f615107 Cu	2 1/2"	75	207	130	42	86	0,48
	ST 08	f615108 Cu	3"	88	219	142	42	92	0,54
	ST 09	f615109 Cu	4"	113	250	175	42	92	0,62
Rozsdamentes	ST 01	f615101 A2	1/2"	21	104	50	30	40	0,25
	ST 02	f615102 A2	3/4"	26,5	112	58	30	44	0,26
	ST 03	f615103 A2	1"	33	137	72	35	53,5	0,32
	ST 04	f615104 A2	1 1/4"	42	149	84	35	59,5	0,36
	ST 05	f615105 A2	1 1/2"	48	155	90	35	62,5	0,37
	ST 06	f615106 A2	2"	60	189	112	42	77	0,39
	ST 07	f615107 A2	2 1/2"	75	207	130	42	86	0,43
	ST 08	f615108 A2	3"	88	219	142	42	92	0,48
	ST 09	f615109 A2	4"	113	250	175	42	92	0,55

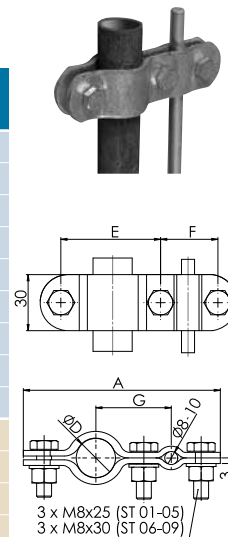

ERESZCSATORNA - CSŐBILINCS CONNECTING CLAMP FOR DOWNPIPES

Anyag (Material)	Cikkszám (Code)	(Part no.)	D (mm)	D1 (mm)	Súly (Weight) kg
Fe/Zn	ST 10	f615215	50 - 140*	8 - 10	0,60
	ST 11	f615225	140 - 240*	8 - 10	0,84
Réz	ST 10	f615215 Cu	50 - 140*	8 - 10	0,59
	ST 11	f615225 Cu	140 - 240*	8 - 10	0,98
Rozsdamentes	ST 10	f615215 A2	50 - 140*	8 - 10	0,47
	ST 11	f615225 A2	140 - 240*	8 - 10	0,79

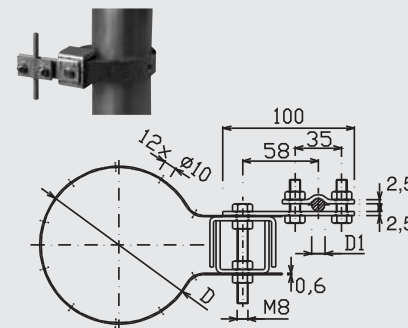

KAPOCS Ø20 FÖLDELŐRÚDHOZ CLAMP FOR EARTHING ROD Ø20

Materiál (Material)	Označenie (Code)	Obj.č. (Part no.)	L1 (mm)	L2 (mm)	Hmotnosť (Weight) kg
Bronz / Brass	S2F	f000190	40,0	41,0	0,088

